



Where Quality Counts

Introduction

Environmental control of working and living conditions are playing an increasingly important role in business as well as personal life. Numerous functions are being automated to increase efficiency, to improve comfort or simply to be able to master certain tasks that otherwise would be impossible to accomplish. Basic mechanical functions are becoming highly automated. For many years now, garage doors are being opened automatically, production processes are extensively automated and today building environments are fully controlled by computers. At the core of all these functions are, as a rule, electrical motors that carry out the actual functions for which timing, speed and duration are controlled by sophisticated electronic systems.

Elero is a key supplier of specialty motors that handle numerous functions designed to help facilitate and control the residential and business operating environments. The primary motor applications are rolling and lifting functions to operate shading systems, window covering systems, awnings, shutters, rolling doors, insect screens and various light industrial uses. Tubular motors are the primary operators for these applications.

The concept of the tubular motor is both amazingly simple and extremely reliable. The motors are encapsulated in a secure tubular metal housing. The entire motor unit is concealed in an operating tube that serves simultaneously as the support and the rotating drive shaft for any of these systems listed above, awnings, shades, shutters, etc. Since the motors are fully incorporated in the finished product there are no exposed parts or components. This ensures a clean look and reduces the risk of damage to the motor or interference with its operation.

Standard Elero motors are equipped with mechanical end-stops for the up and down movements that can conveniently be set, changed or adjusted. Once the stops are set, the system will automatically shut off every time they reach the desired position. Switching on and off of both systems can be done by a wide selection of controls. Elero offers a full line of its own controls ranging from simple switches to low voltage central or decentralized controllers, timers and sensors.

The following pages provide an overview of these systems, schematics for wiring within the overall electric circuits, and detailed wiring information for the hook-up of the individual components. If any questions arise, please contact our technical department at 1-800-752-8677.

Motor Range

Elero offers tubular motors in a wide range of torque capacities for use in shutters, awnings roller shades and many light industrial applications. The company also offers square lift motors primarily designed to operate venetian blinds, as well as various box motors to operate overhead and roll up doors. The most widely used tubular motors are 2-inch and 2-1/2-inch tubular motors with capacities ranging from 5 to 100 Nm. Additional heavy duty motors are available on special request. Depending on the type of application, different rotating speeds may be required. Elero offers a high-speed motor operating at 80 rpm which is particularly well suited to raise insect screens as well as tall roller shades. Most models are available with a manual override to permit operation in case of power interruption which may occur due to severe storms or accidents.

Motor Type	Motor Diameter OD (Inches)	Torque NM	RPM	Manual Override
8/03	1.38	3	27	No
8/05	1.38	4	15	No
9/07	1.81	7	30	No
9/1/30	1.81	10	30	No
9/1	1.81	10	16	Yes
9/1.8	1.81	18	16	Yes
9/2.5	1.81	25	12	Yes
9/3.3	1.81	33	12	Yes
9/4	1.81	40	12	Yes
9/05/80	1.81	5	80	No
11/4	2.32	40	18	Yes
11/6	2.32	60	13	Yes
11/8	2.32	80	14	Yes
11/10	2.32	100	10	Yes

The Control program further includes digital timers, light sensors, wind and humidity sensors. Specialty controllers are available upon request.



Where Quality Counts

Elero Control Equipment

Switches

Since Elero motors are equipped with dual coils to permit rotation selection forward or reverse, all switching and control devices must allow for this selection. All Elero switches are therefore so-called double throw/three position switches (up-stop-down). These are available as rocker and key switches. Both infrared and radio control systems are being offered. The infrared system can operate up to 12 separate motors off of one hand controller without the risk of interference.

Do Not Wire Standard Motors In Parallel

Elero motors are single phase reversing motors which cannot be connected in parallel. When it is desirable to run more than one motor from a single switch or operating signal, the inactive motor coils must be isolated. This requirement necessitates some type of interfacing control in all installations where motors are grouped for simultaneous operation.

Isolated Relay

This is a term used in the industry to refer to a specially wired relay associated with each motor which serves to disconnect the inactive motor coil and allows parallel wiring of motors at the switching device. The isolated relays can be located anywhere in the wire run to the motor. They are often located in the junction box near the motor, or within the enclosure of the application itself. These isolated relays are furnished by Elero as a sealed component with a six inch wire lead both in and out. While the isolated relay works well for a small group of motors, it does require one for each motor and the total operating current of all motors passes through the switching device. The amperage rating for the switch has to accommodate the total current load. Motors cannot be operated independently in this type of group.

Elero Control Equipment

Relay Group Controls

This technique provides multi-pole relays in a single enclosure such that each motor has its own relay switching poles. Since common relays are furnished as 4-pole devices, the common group control arrangements are for 4, 8, and 12 motors. This type of arrangement will allow individual motor switches, in addition to the group switch. The relay circuit design provides an override of the individual switches when the group is activated. The motor operating current does not pass through the switching device. The disadvantages are that the 120v power wiring for each motor must be run as a separate circuit back to the main group control. With large groups, the total power requirements must be considered. The individual switches can only be used if the main switch is in the off position. Momentary switches must be used for individual switches requiring an operator to hold the switch while making individual adjustments.

All individual Elero motors are single phase reversing motors and cannot be connected in parallel. When it is desirable to run more than one motor from a single switch or operating signal, the inactive motor coils must be isolated. This requirement necessitates some type of interfacing control in all installations where motors are grouped for simultaneous operation.

Motor Control Units

The most versatile technique provides each motor with its own control to provide the switching of the 120v power to that motor. Elero low voltage controls offer an ideal solution for such decentralized control of multiple units in groups, subgroups and individual units. In this system, a motor control unit (MCU) is placed convenient to each motor and a local source of 120v power is wired up to the control. All MCU's are then connected with a low voltage cable. The 24V DC control power and group switching signals are transmitted over the low voltage cable. Sub-group controls allow numerous grouping configurations. Individual switching devices can be connected to the individual MCU's, Sub-Group or Main Group controllers as required. Each controller can have different or multiple switches (IR, Radio, Sun Sensor, Etc.). All control signals, either individual or group, are momentary with the duration of the power to the motor being controlled by the motor control unit. Each motor can be started and stopped independently or as a group. All switching is low voltage and can be incorporated in automation systems.

In addition to these standard interfacing group and controls, Elero offers many options for custom systems. Contact Elero Engineering to review any special requirements.

Motor Wiring System

Elero tubular and JM motors are asynchronous reversible motors. Each motor is provided with a four conductor power cable containing a green ground, white neutral, and red and black power leads. Power applied to the black and white wires produces rotation in one direction, power to the red and white wires results in rotation in the opposite direction. At no time should power be applied to both the black and red wires simultaneously.

The basic electrical system consists of the incoming power supply, a switch and the motor.

The System

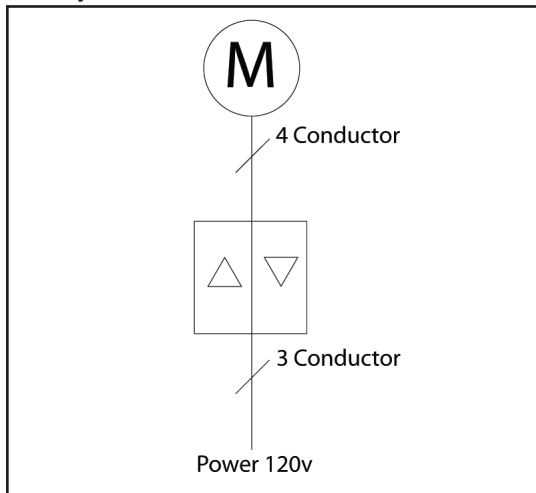

The Electrical Schematic

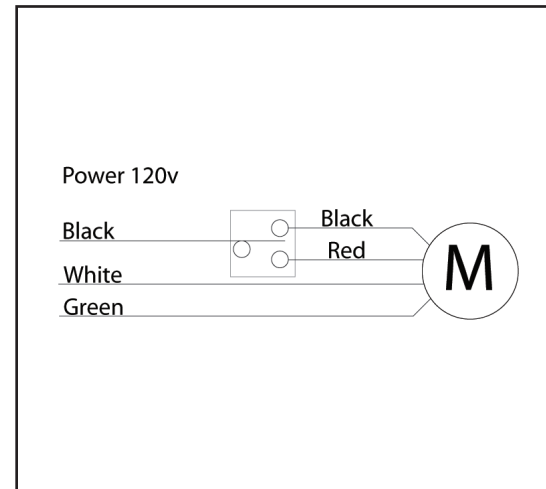

The Actual Wiring

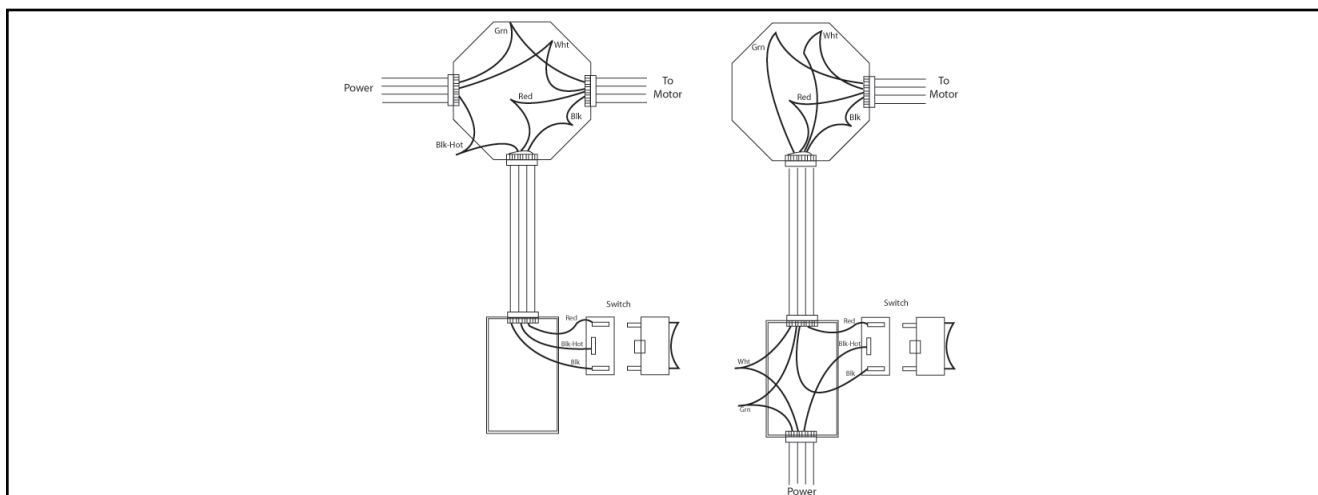

Elero offers a wide choice of switching devices that can be used instead of the manual switches shown here. The 3 conductor power input and 4 conductor output to the motor are consistent for all of these. The wiring of the actual switching devices will differ and are detailed in this catalog.

SPDT Rocker Switches



Rocker switches are recessed mount and are available in momentary or maintained contact. Single cut-out cover plate standard with switch, for custom size plates contact factory. Rocker switches are standard in white, for custom colors contact factory.

Voltage	125v AC / 250v AC
Amperage	15A / 10A
J-BoxSize	2" x 4"

SPDT Rocker Switch (Single Pole Double Throw)

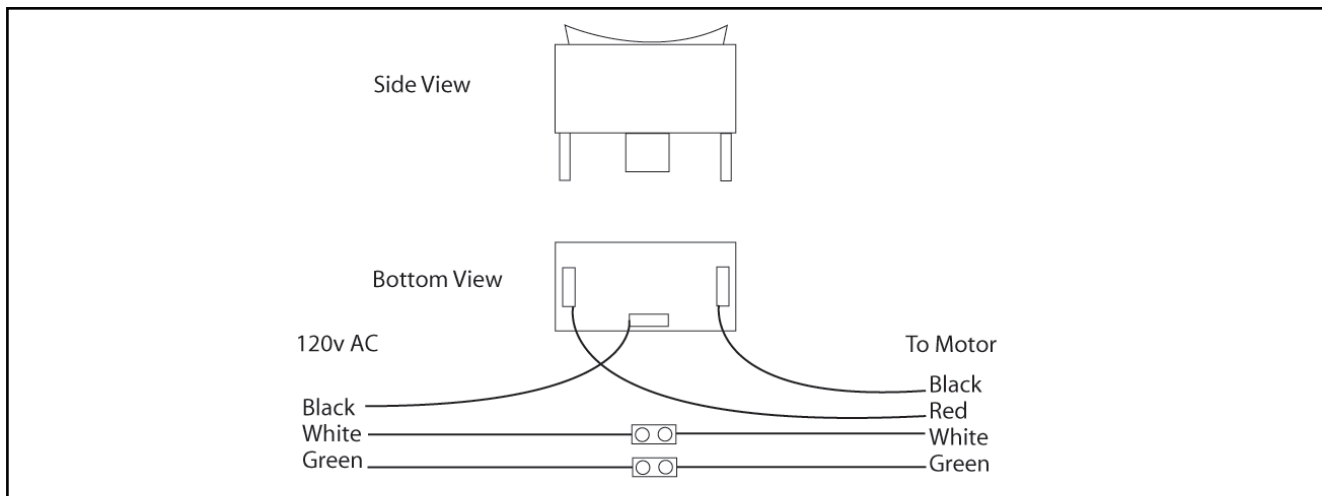
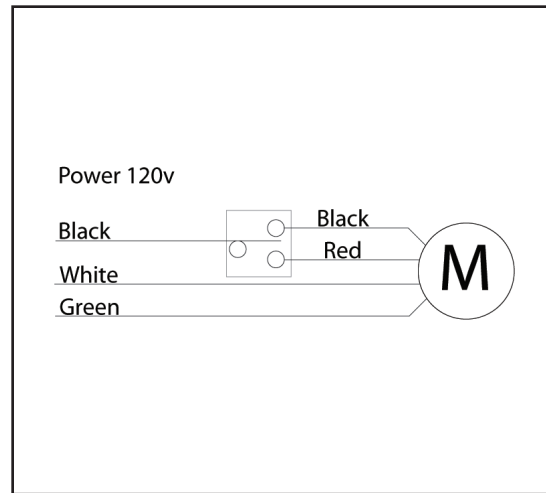
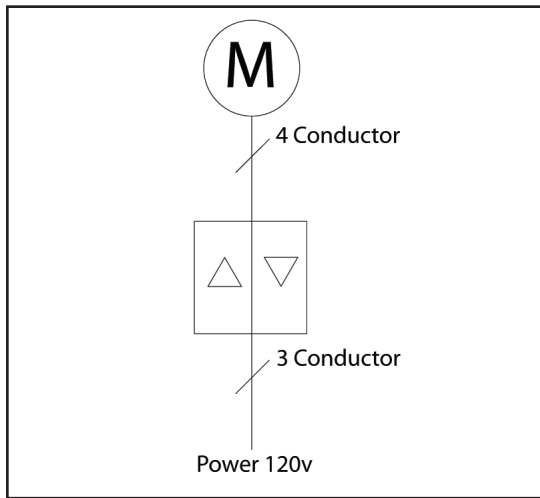

DPDT Rocker Switches



Rocker switches are recessed mount and are available in momentary or maintained contact. Single cut-out cover plate standard with switch, for custom size plates contact factory. Rocker switches are standard in white, for custom colors contact factory.

Voltage	125v AC / 250v AC
Amperage	15A / 10A
J-BoxSize	2" x 4"

DPDT Rocker Switch (Double Pole Double Throw)

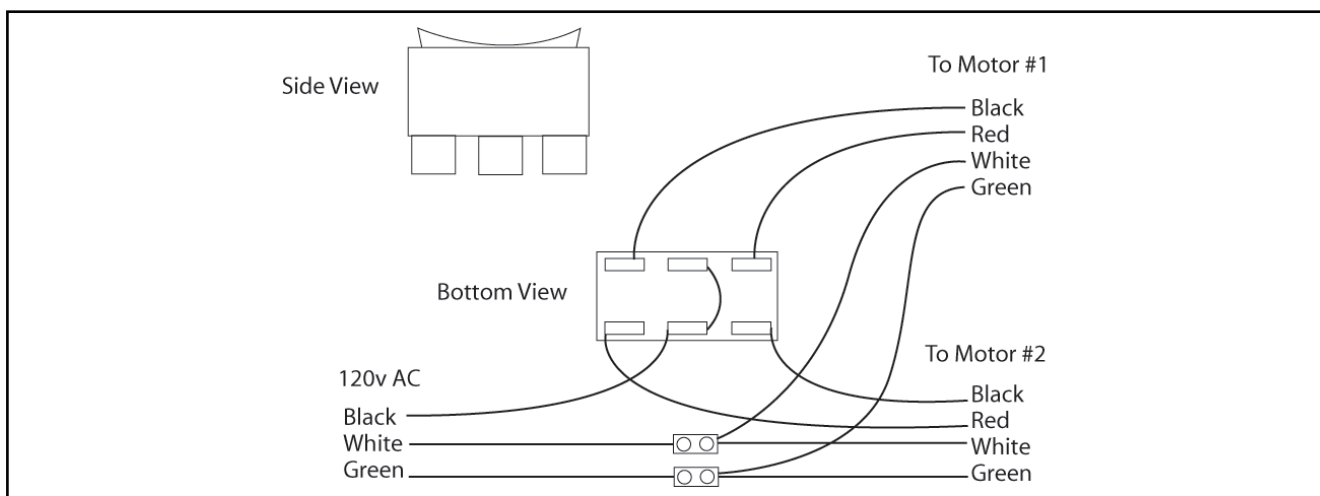
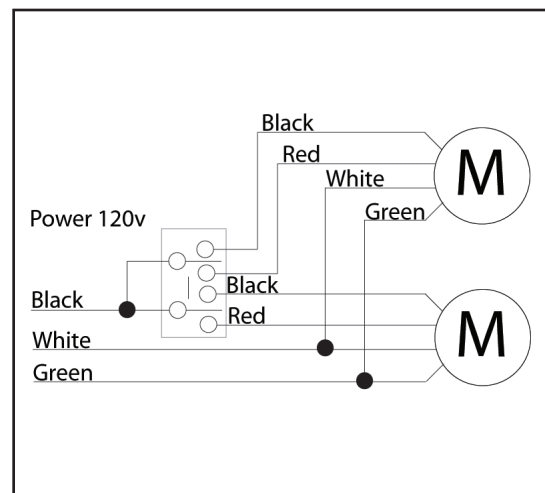
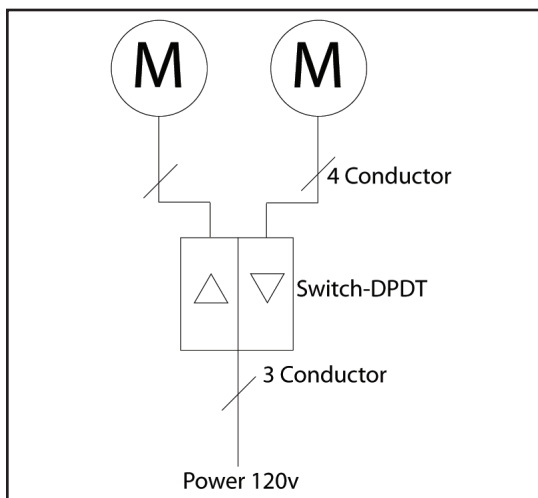

Interior Key Switches



Elero interior key switches are available in SPDT or DPDT and are standard with 2 keys. Recommended for interior use only, unit is not weatherproof.

Voltage 600v AC
 Amperage 10A
 Furnished with metal cover plate
 Recessed Mount
 J-BoxSize 2" x 4"

Interior Key Switch

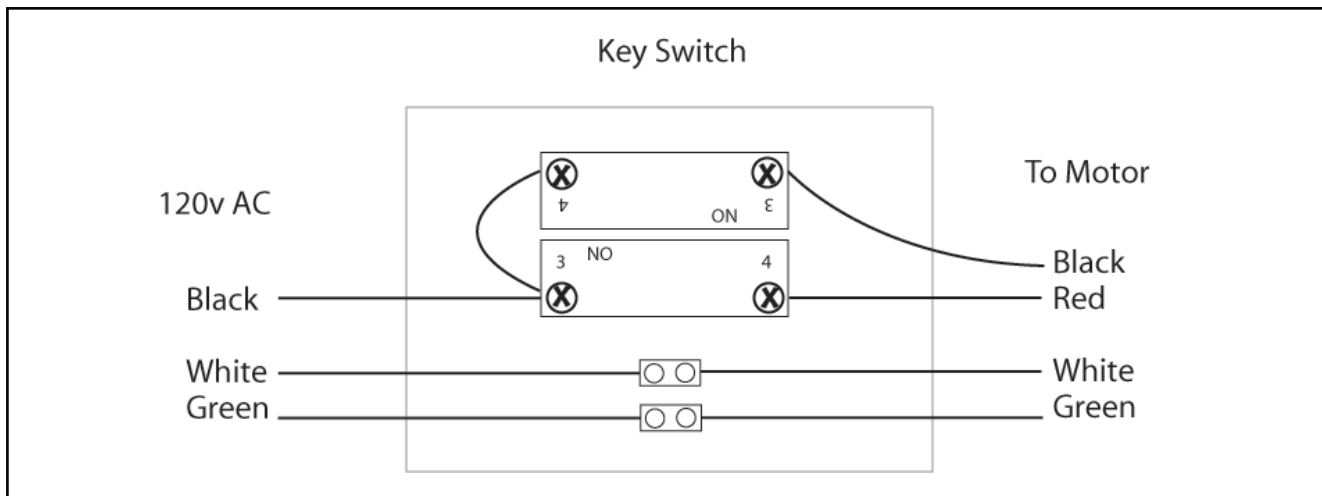
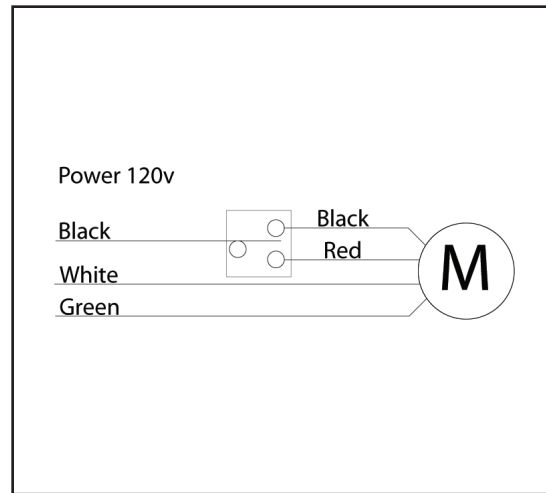
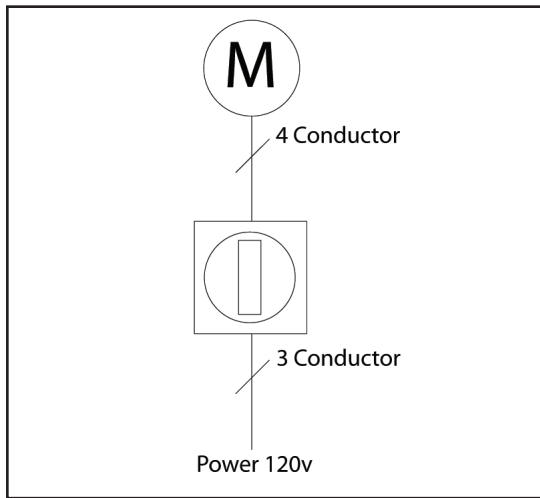

230 Volt Switch



Rocker switches are recessed mount and are available in momentary or maintained contact. A single cut-out cover plate is standard with switch, for custom size plates, contact factory. Rocker switches are standard in white, for custom colors, contact factory.

Voltage	125v AC / 250v AC
Amperage	15A / 10A
J-BoxSize	2" x 4"

230 Volt Switch (Double Pole Double Throw)

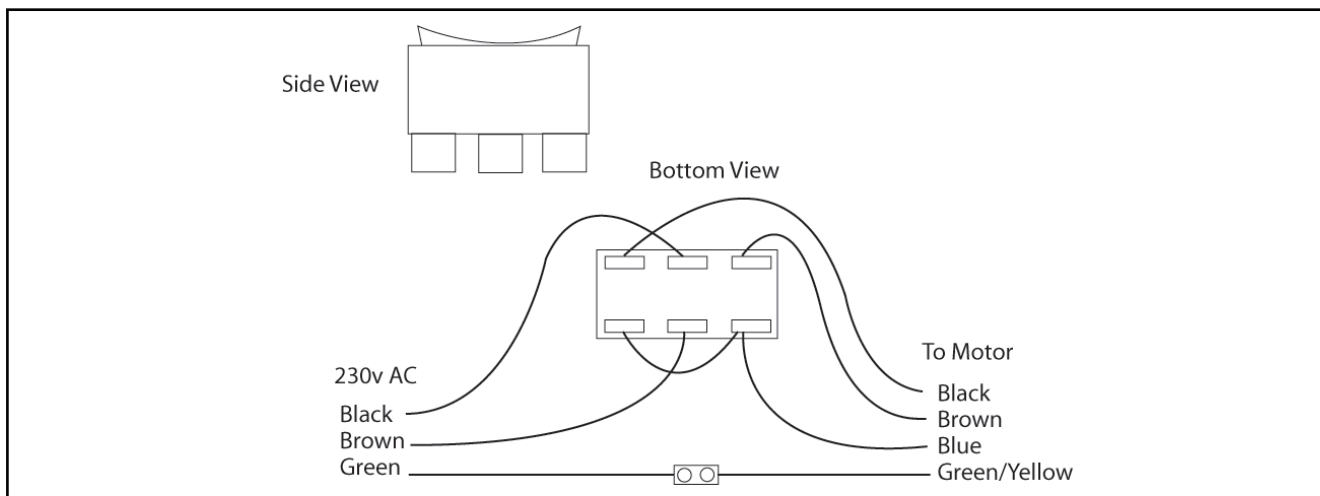
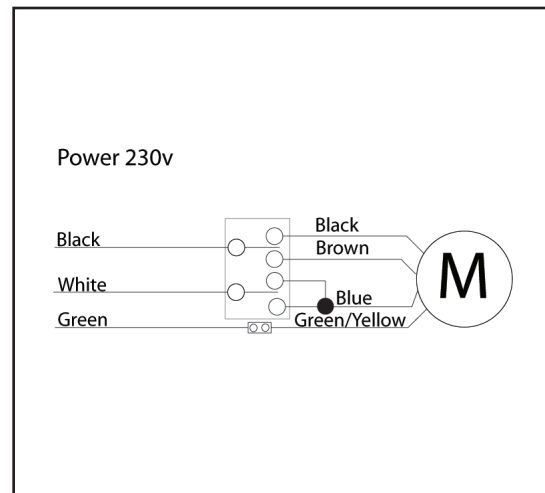
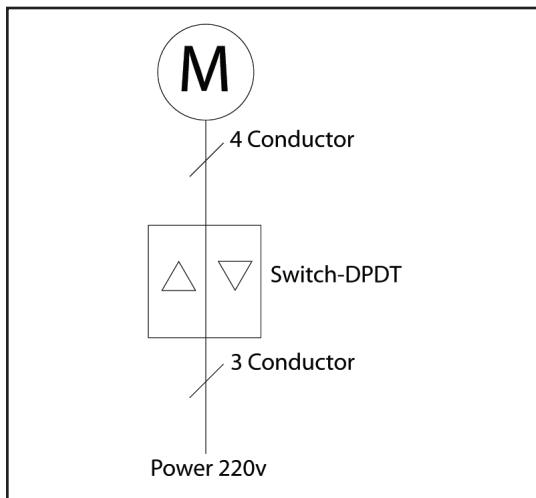

Hirschmann Plug ST

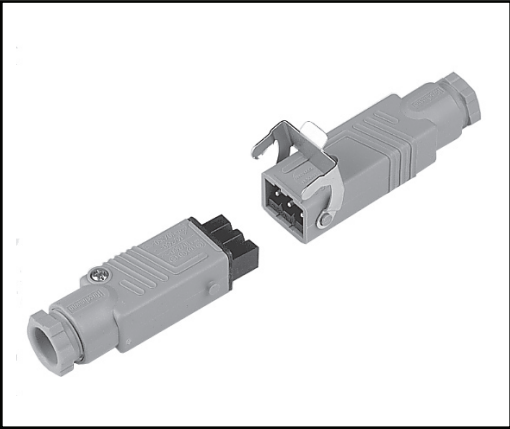

Used for plug type connections between the switch and the motor. IP 54 enclosure. Furnished with strain relief.

Rating for 380v AC/ 450v DC
 16 AMP
 Max Wire Gage 16
 3 Pole + ground

Hirschmann Plug

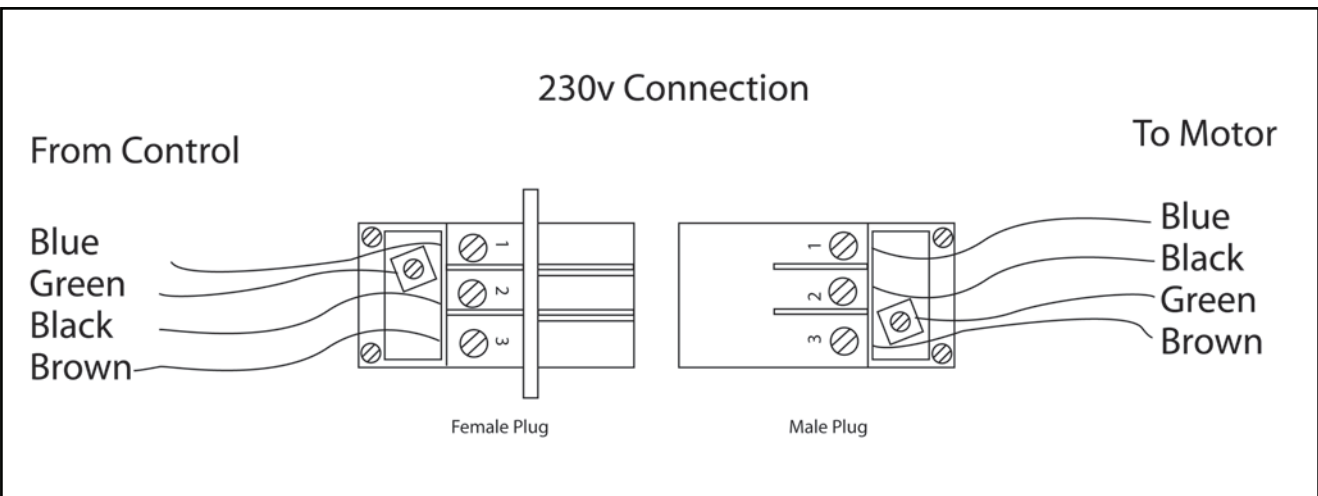
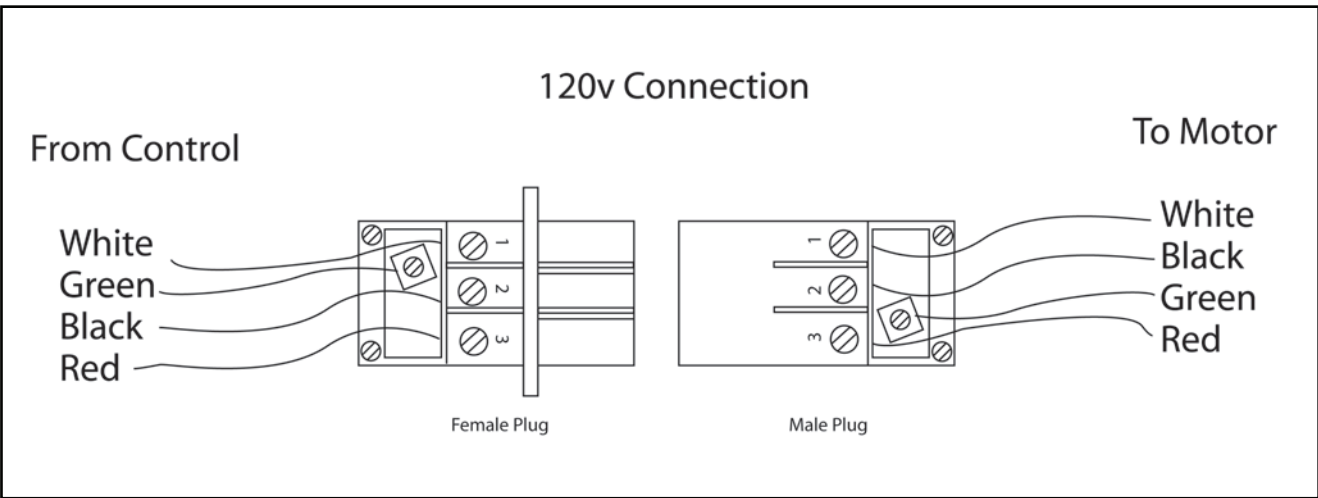

Hirschmann Plug CA



Used for plug type connections between the switch and the motor. IP 67 enclosure. Furnished with strain relief.

Rating	for 380v AC/ 250v DC
	16 AMP
Max Wire Gage	16
3 Pole + ground	

Hirschmann Plug

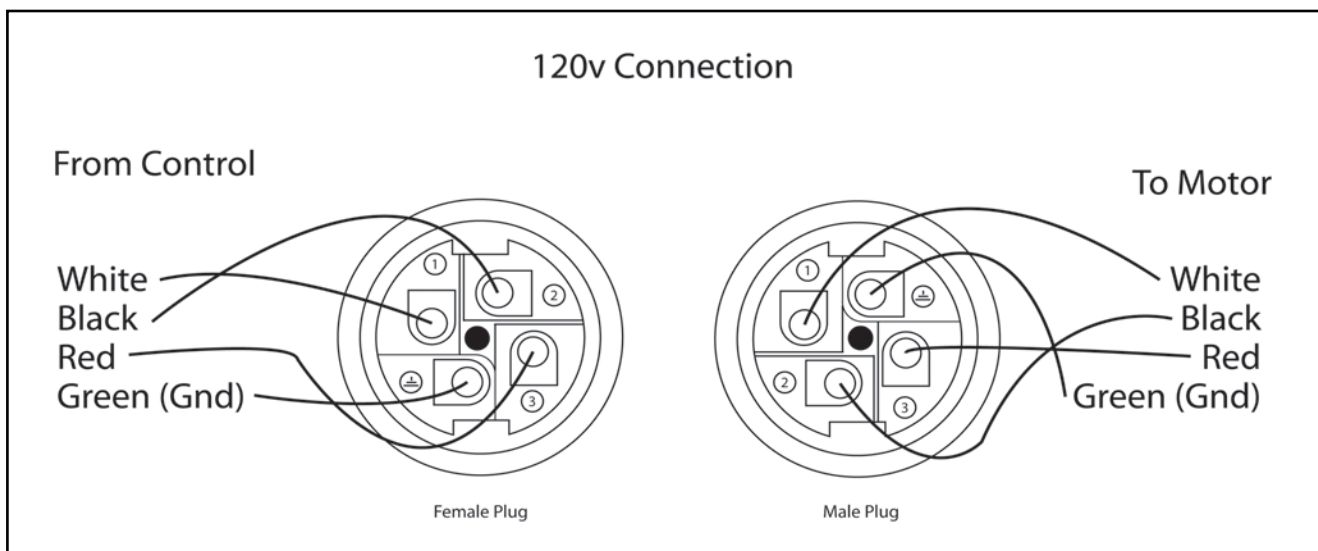

PEZ-R



Allows for shades to be raised or lowered automatically up to 16 times a day, 7 days a week. Can be used with group controls to operate numerous motors simultaneously or by itself to control a single 110v motor.

Voltage	110-120v AC
Frequency	60Hz
Amps	4
Capacity	480v A
Operating ambient temp.	-5 C to +50 C
Output duration	30-3 minutes
Program record	16
Power reserve	6 months
Accuracy	+2 seconds
Housing size	2-3/4" W x 2-3/4" H x 3" D

PEZ-R

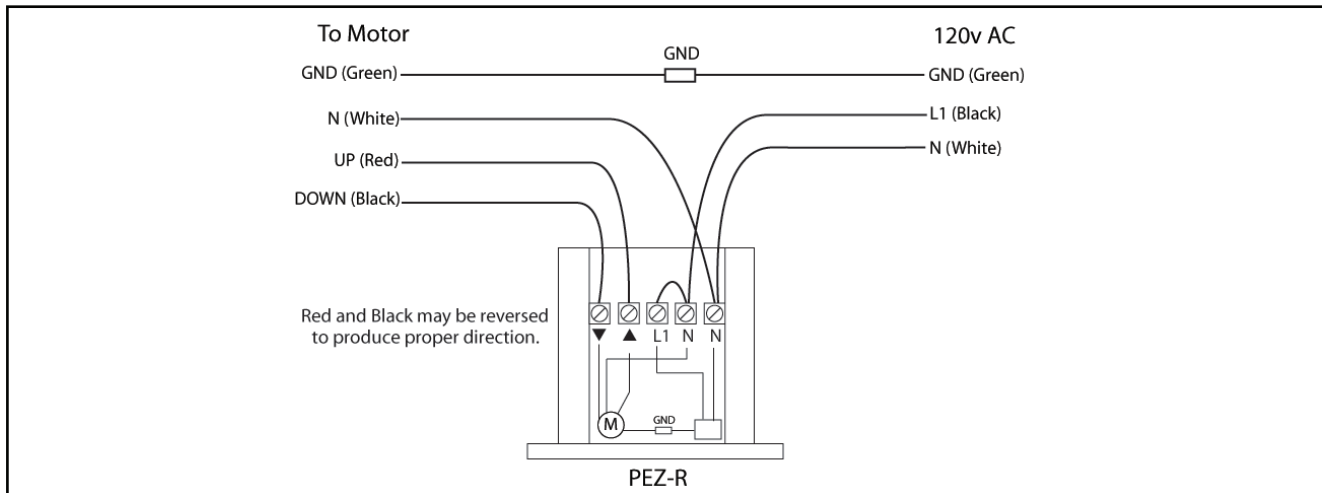
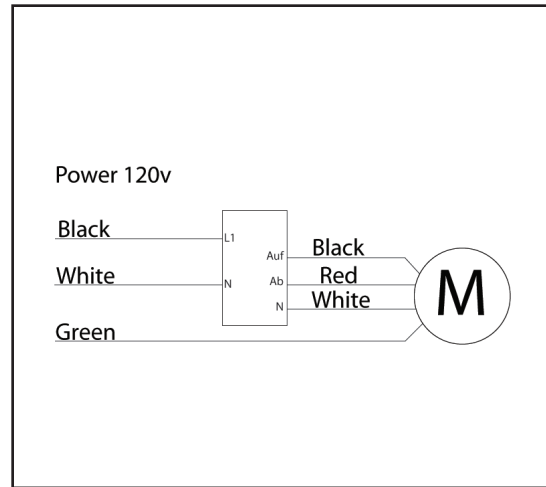
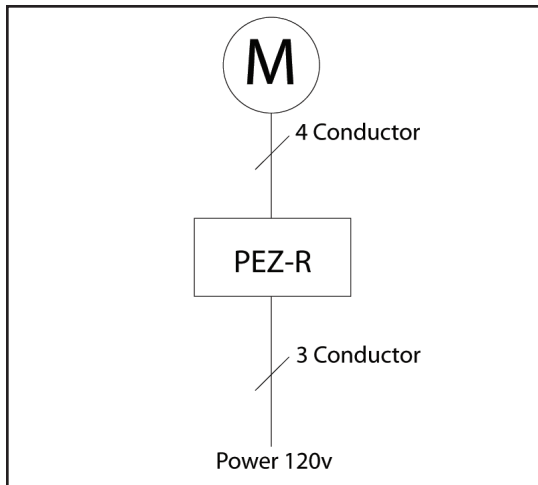

PEZ-RS

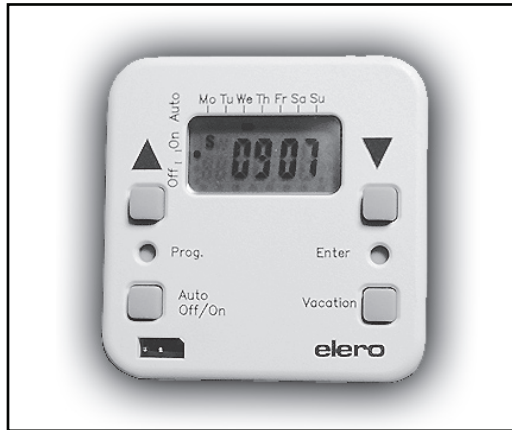

Functions as a digital timer or can be set to raise or lower shades by sensing sunlight. Can be used with group controls to run numerous motors simultaneously or by itself to run a single 110v motor.

Voltage	110-120v AC
Frequency	60Hz
Amps	4
Capacity	480v A
Operating ambient temp.	-5 C to +50 C
Output duration	30-3 minutes
Program record	16
Power reserve	6 months
Accuracy	+2 seconds
Housing size	2-3/4" W x 2-3/4" H x 3" D

PEZ-RS

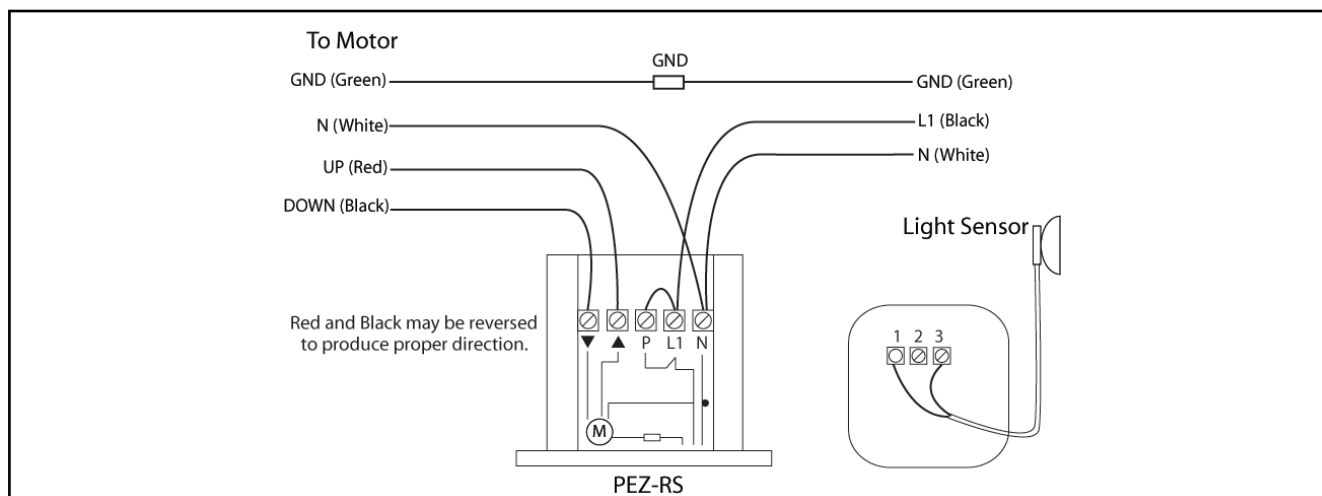
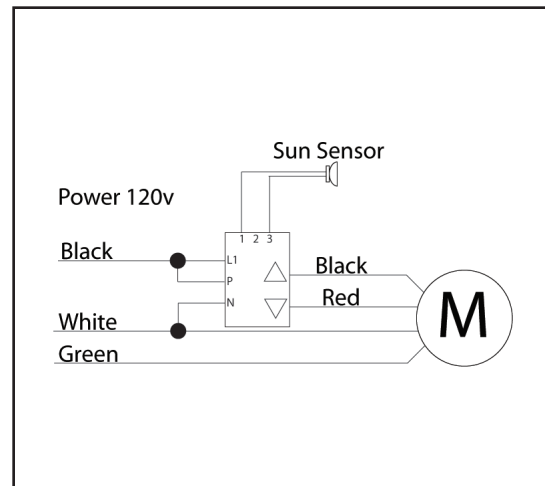
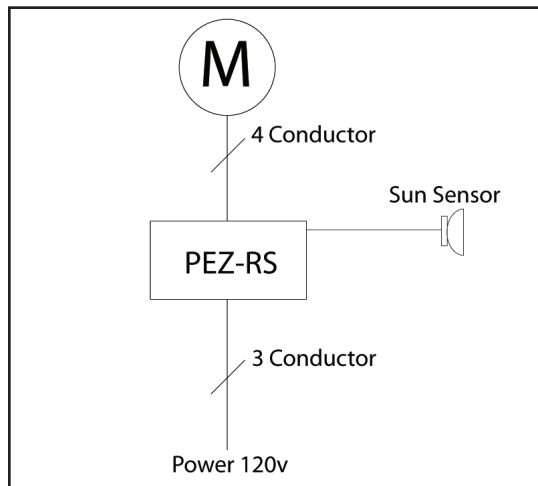

Sonneboy

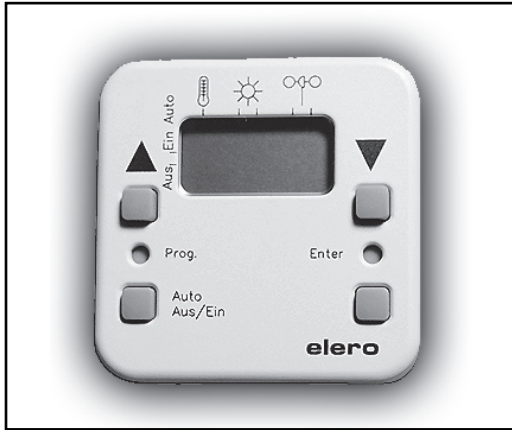

Sonneboy

The microprocessor-based Sonneboy offers continuous sun/wind protection. The Sonneboy controls the installation according to light intensity. The assembly includes both sun and wind sensors which can be used individually or together. The wind sensor is active in both manual and automatic operating modes.

Voltage	110-120v AC
Frequency	60Hz
Amps	4
Capacity	480v A
Operating ambient temp.	-5 C to +50 C
Output duration	30-3 minutes
Power reserve	6 months
Housing size	2-3/4" W x 2-3/4" H x 3" D

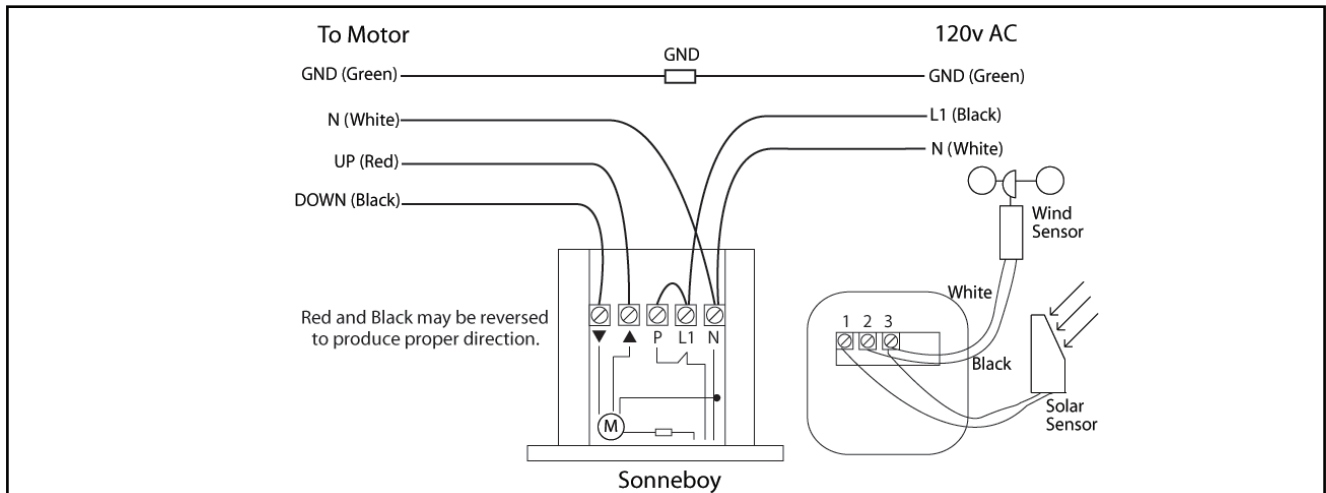
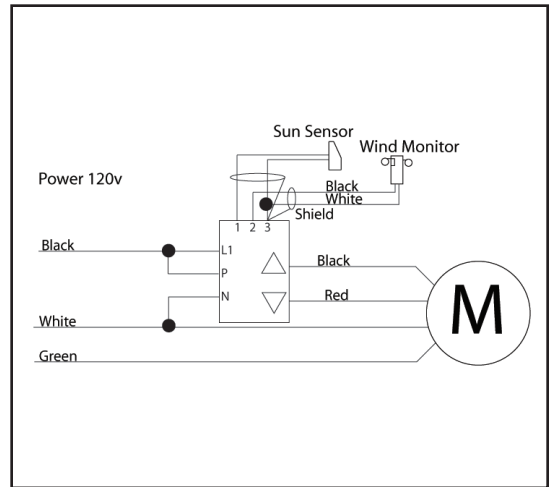
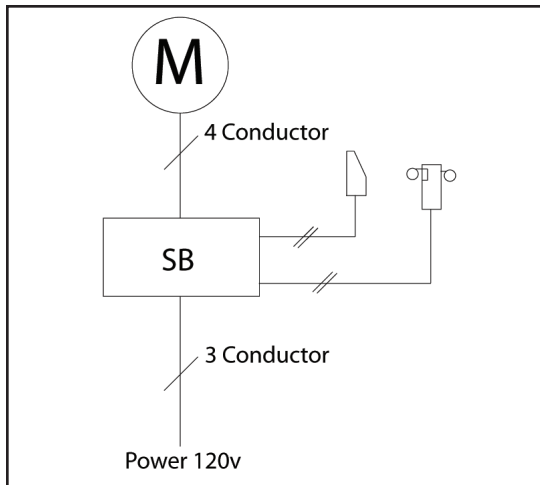

WKS-IR Receiver



Remotely controls a single 110v motor from up to 60 feet away. Processor face plate doubles as a manual override switch. The 110v receiver has a 3 minute maintained contact

Voltage	110-120v AC
Frequency	60Hz
Amperage	4A
Capacity	480v A
Operating ambient temp.	-5 C to +50 C
Output duration	3 minutes
Housing Size	2-3/4" W x 2-3/4" H
Face plate available in white or almond	

WKS-IR AC Receiver

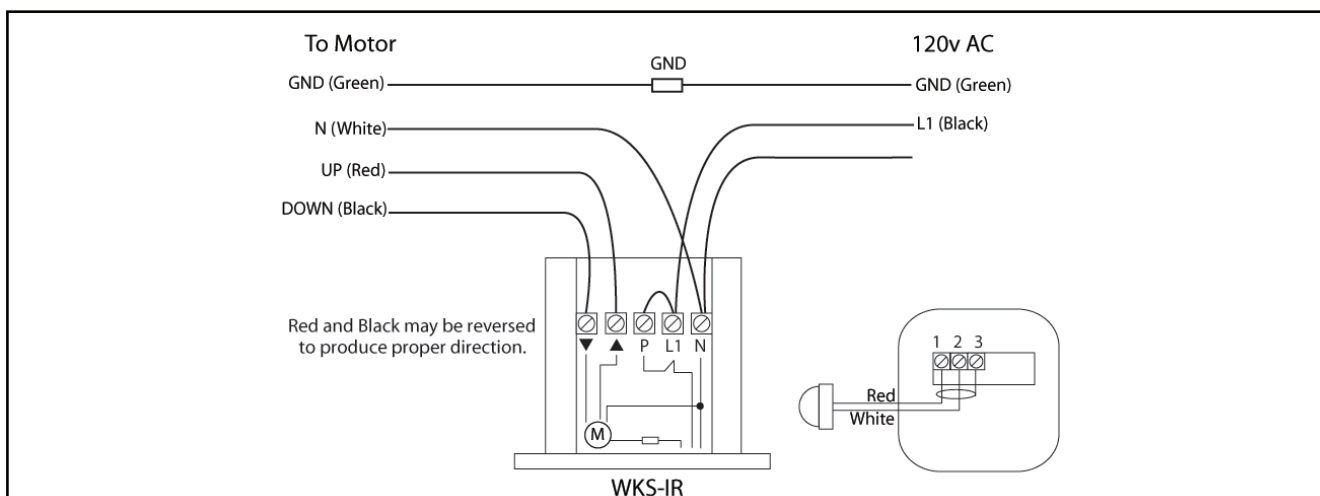
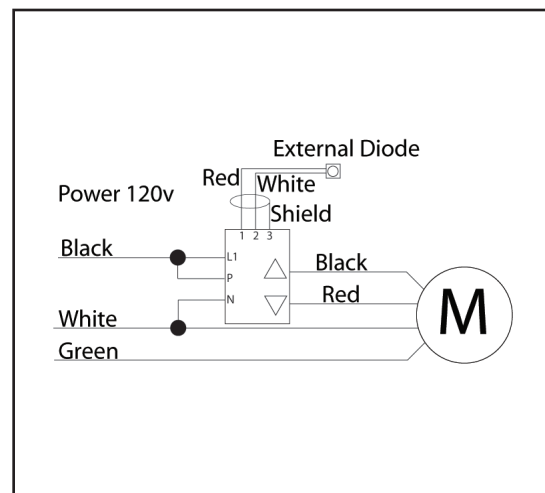
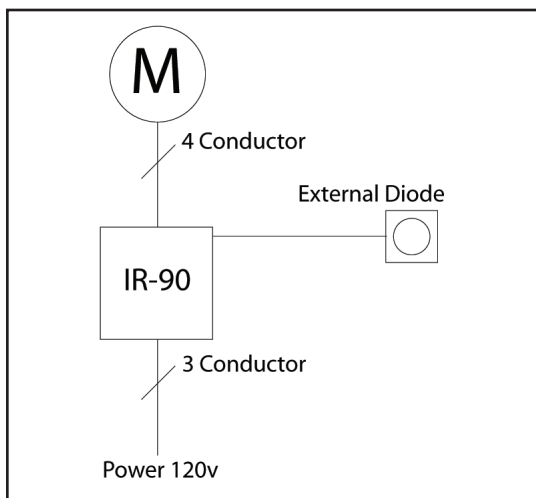

AC Group Control

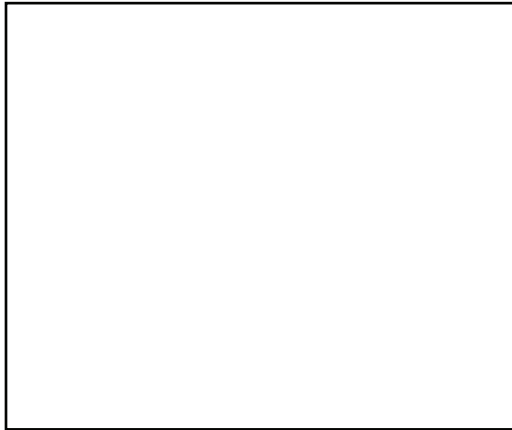

Used in applications where it is necessary to operate more than one 110v system simultaneously from one control. Hook-ups from manual override of individual systems are also built-in to accommodate different applications of groups, subgroups, and individual operation.

Voltage	110v AC
4 Units	8 max Amps (10 x 10 x 4 beige box)
8 Units	15 max Amps (12 x 12 x 4 beige box)
12 Units	25 max Amps (18 x 18 x 6 gray box)

AC Group Control Unit

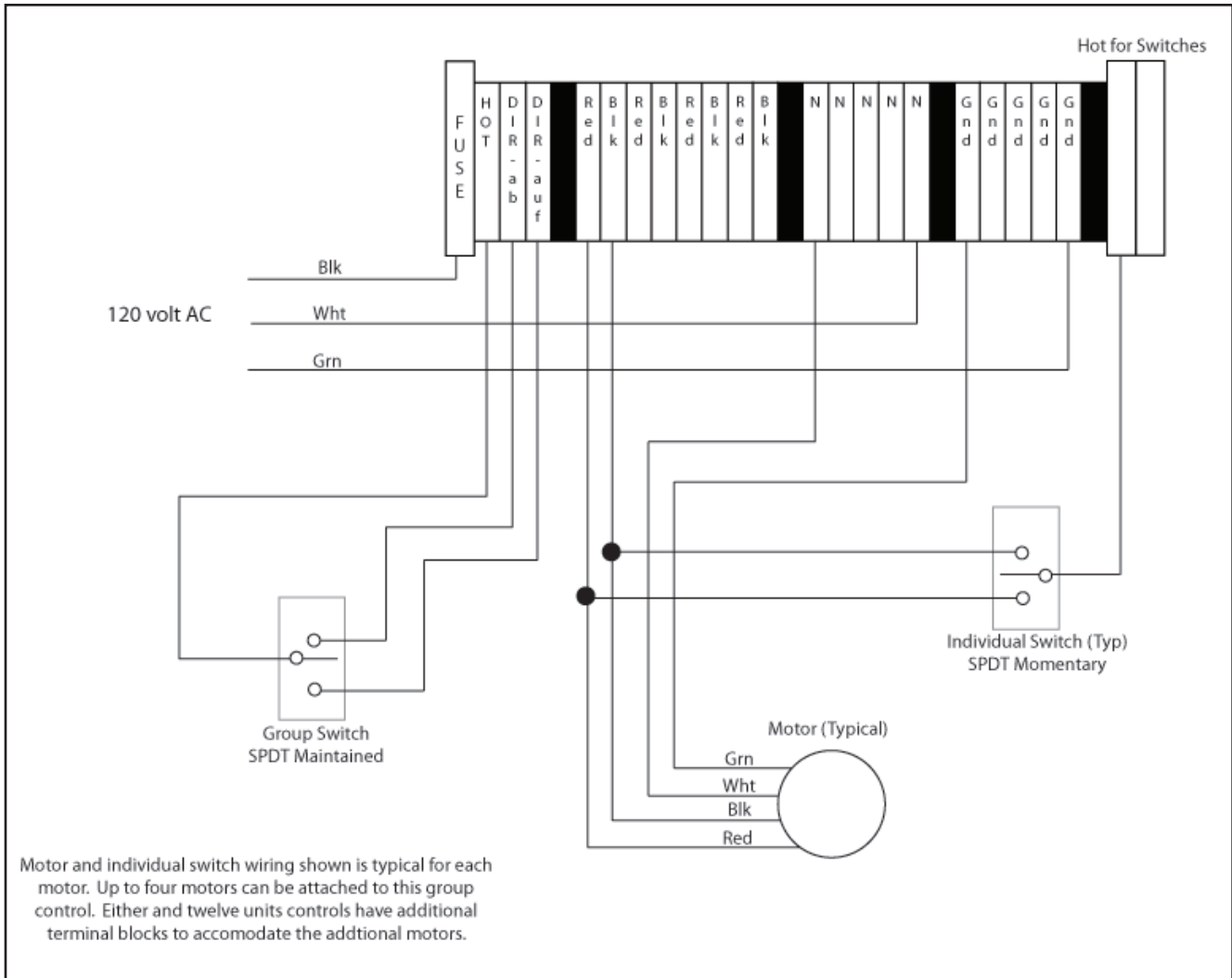

Isolated Relay

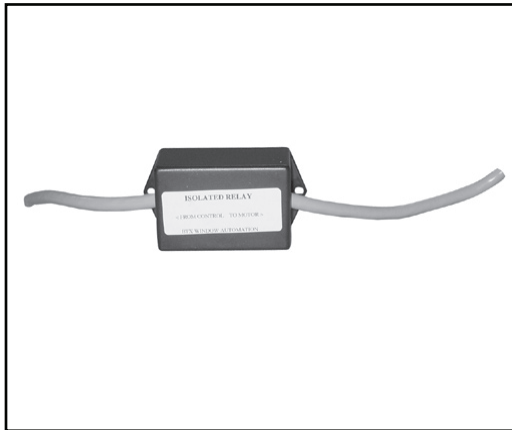

Used to run more than one 110v motor simultaneously from one control. It is packaged in a sealed case with a six inch lead wire at both ends.

DPDT
Contact Rating
1 motor per relay

5 Amps at 240v maximum

Isolated Relay

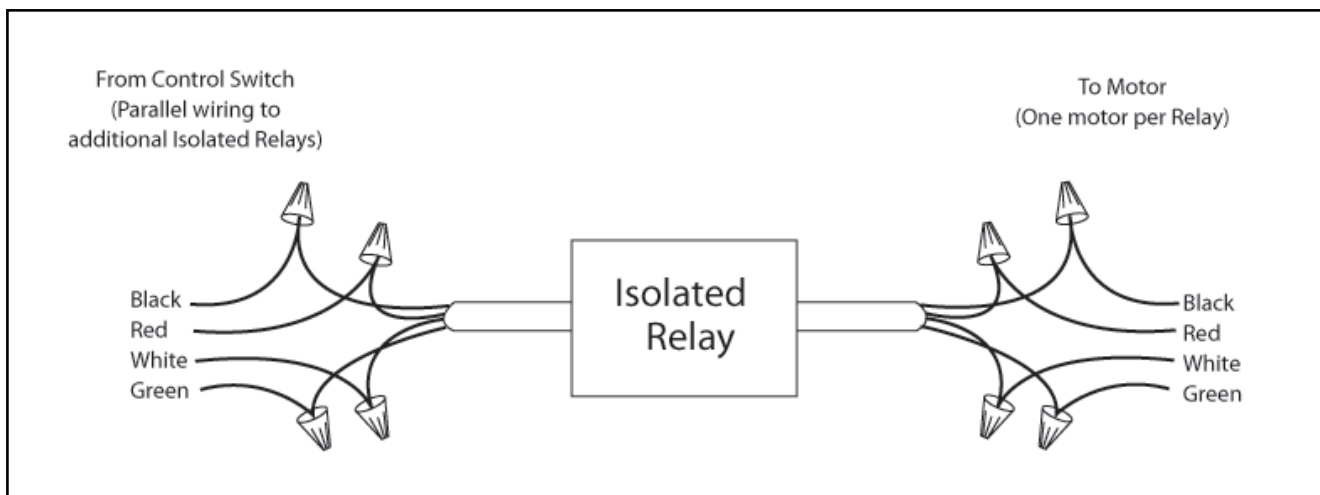
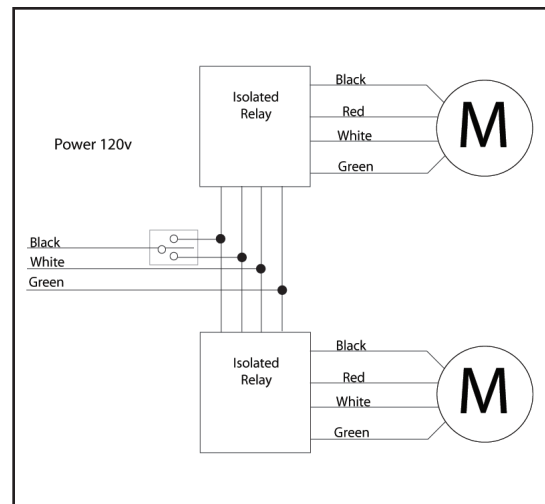
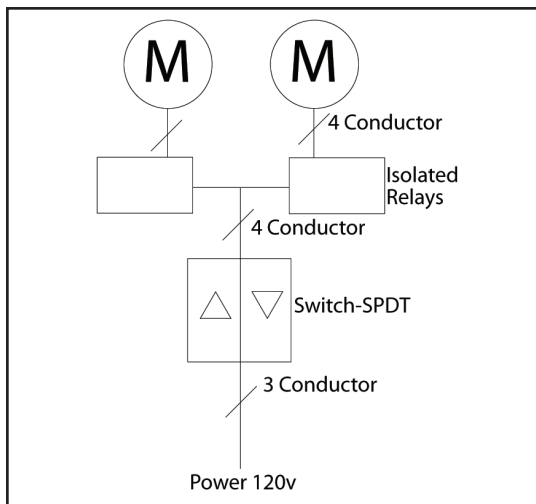

Motor Control Unit MCU-90

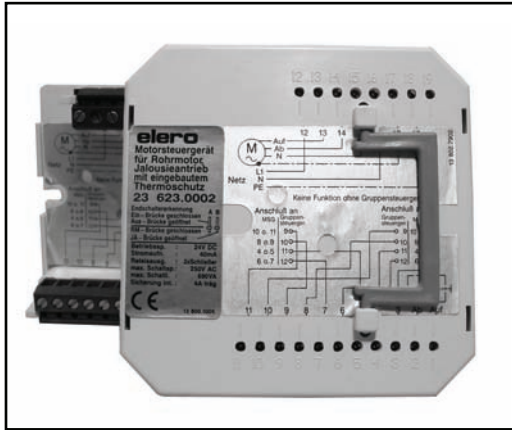

Required 24v DC power supply. One motor control is required for each motor. Provides for motor operation with momentary low voltage control signals. Includes current sensing for automatic reset at end of motor cycle. Can be set to provide pulse action required for tilt operation

Voltage	24v DC
Amps	40mA
Relays	(2) SPDT
Power Supply	110-120v Ac
Max Consumption	690 VA
Max Current	4A
Dimension	93 x 93 x 42 (in mm)

Motor Control Unit

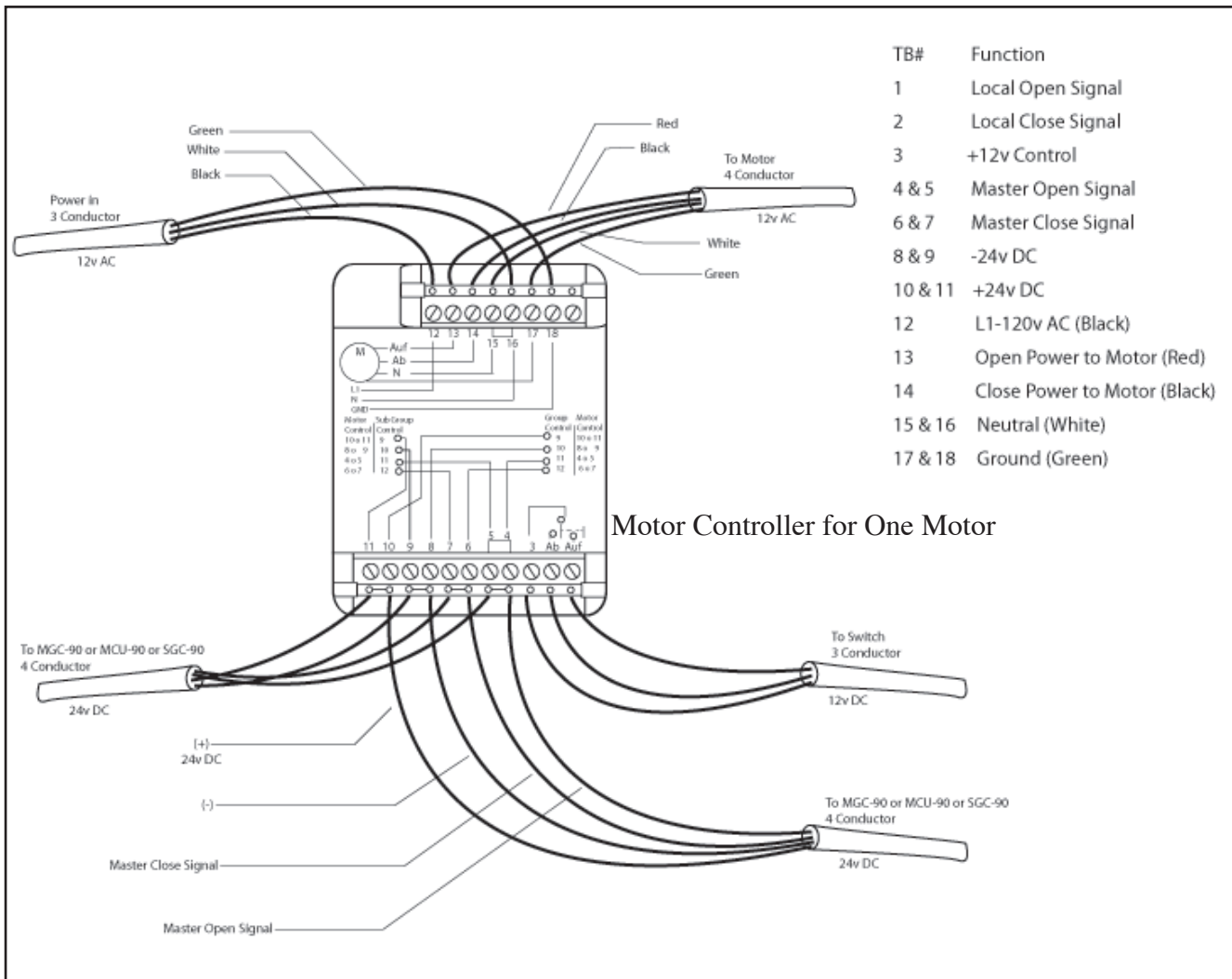

Sub Group Control SGC-90

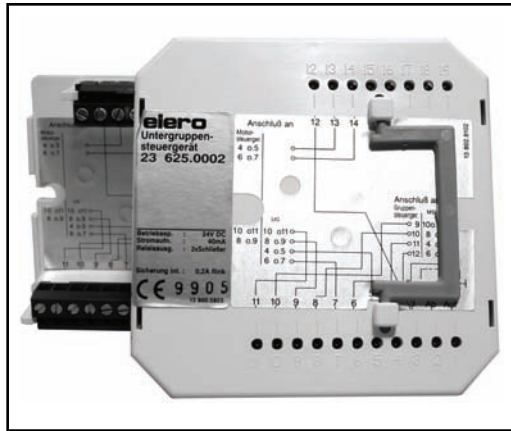

Requires a 24v DC power supply. Allows operation of selected motors within a main control group. To be used in conjunction with MCY-90 only.

Operating Power	24v DC
Amps	40mA
Relays	(2) SPDT
Dimension	93 x 93 x 42 (in mm)

Sub Group Control

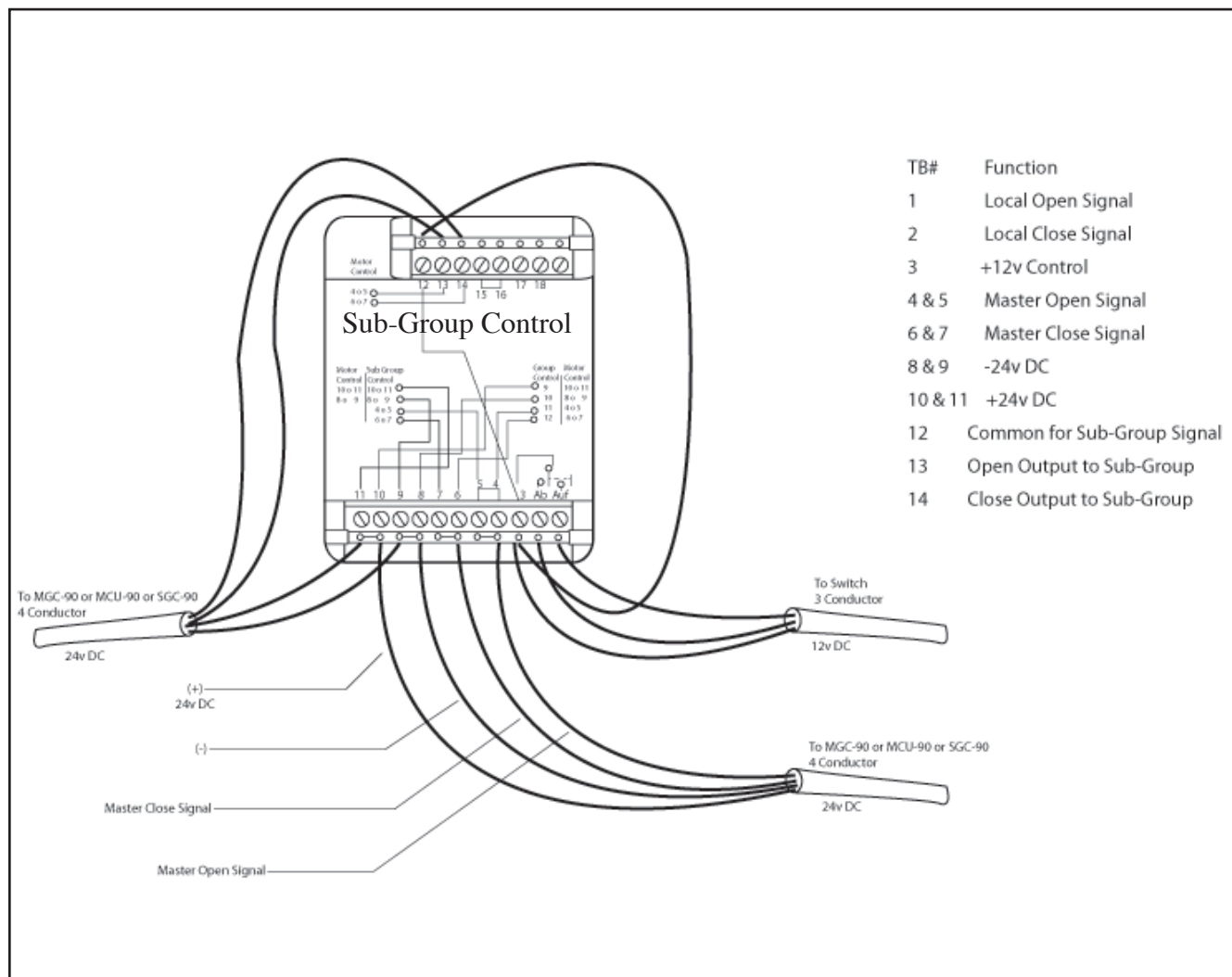

Main Group Control MGC-90



Main Group Control

Main group control including 24V DC power supply. Each group control supplies enough DC power for up to 25 motor controls and sub group controls. For more than 25 units, one additional MGC in parallel for every 25-units increments. Compatible with Elero automated controls

Operating Power	24v DC
Amps	160mA
Frequency	60Hz
Power Supply	110-120v AC
Current	1.2A
Enclosure	IP 40
Dimension	150 x 75 x 112 (in mm)

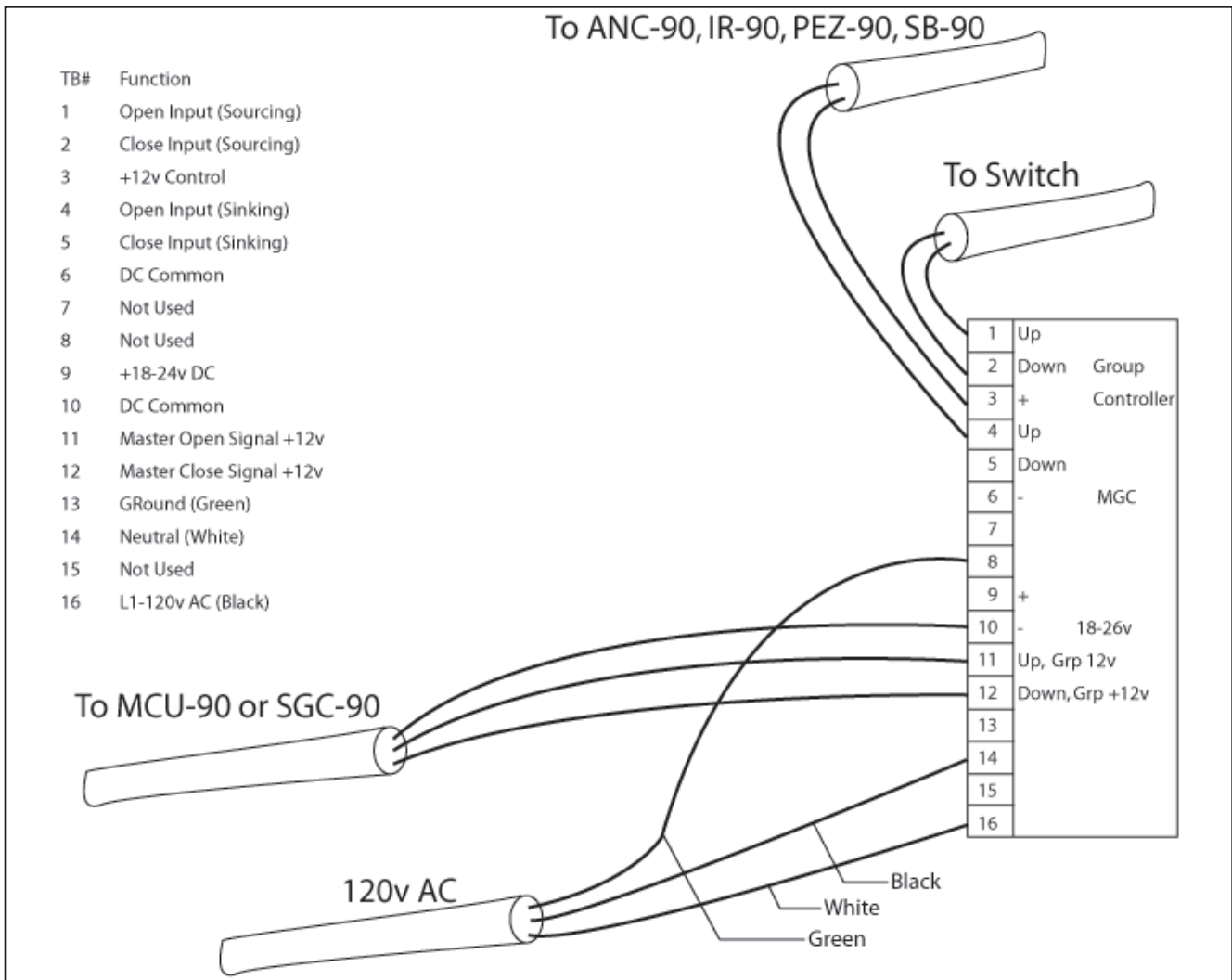

Automatic Network Control Unit ANC-90



Provides sun and wind control for use with MGC-90 and MCU-90. Can also be used with a single 110V motor. Allows adjustment of sun and wind intensity as well as time delay. A manual override button is located on the control enclosure.

Voltage	110-120v AC
Frequency	60Hz
Operating Power	1.5 Induction
Surge Rating	350 Watts
Protection Rating	IP 40
Fuse Rating	10 Amps

Automatic Network Control

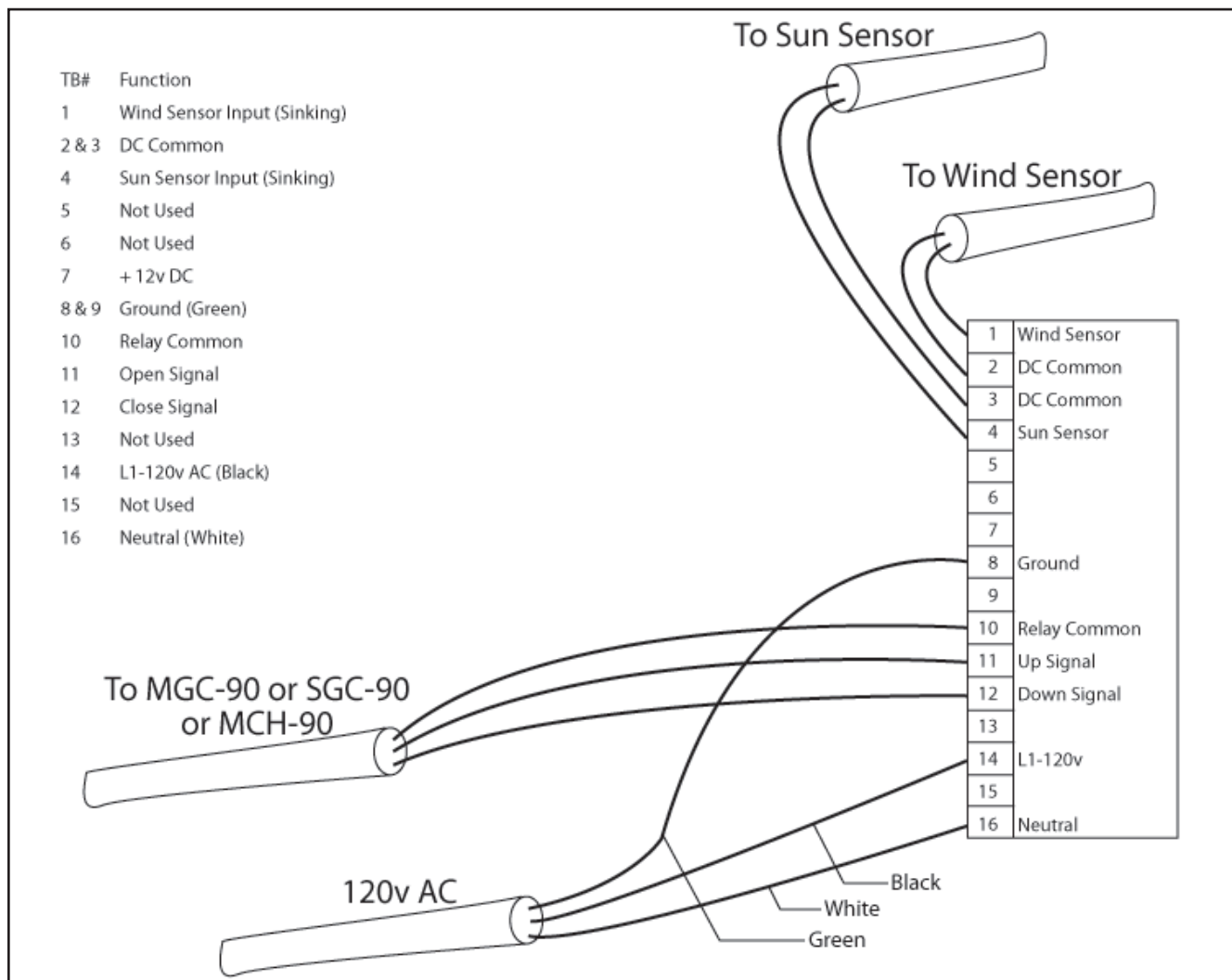



Tubular Motor Overview Chart

Where Quality Counts

Tubular Motors 110 volt/ 60 Hz

Part Number	Type	Motor OD		Torque		Lift Lbs.*2	Rpm	Turns	Power	
		MM	In.	Nm *1	In. Lb.				Watts	Amps
31.871.0001	8/03	35	1.38	3	26	34	27	29	120	1.1
31.861.0001	8/05	35	1.38	5	43	55	15	29	120	1.1
31.312.0001*	9/05/80	46	1.81	5	43	43	80	21/32*	240	2
31.571.0001*	9/07	46	1.81	7	60	61	30	21/32*	200	1.8
31.811.0001*	9/1/30	46	1.81	10	88	88	30	21/32*	200	1.8
31.531.0001*	9/1	46	1.81	10	88	88	16	21/32*	200	1.8
31.511.0002*	9/1.8	46	1.81	18	159	159	16	21/32*	200	1.8
31.521.0001*	9/2.5	46	1.81	25	221	221	12	21/32*	200	1.8
31.232.0001*	9/3.3	46	1.81	33	289	289	12	21/32*	240	2
31.242.0001*	9/4	46	1.81	40	350	350	12	21/32*	240	2
31.031.0003	9/1 MO	46	1.81	10	88	88	16	29	200	1.8
31.041.0003	9/1.8 MO	46	1.81	18	159	159	16	29	200	1.8
31.051.0003	9/2.5 MO	46	1.81	25	221	221	12	29	200	1.8
31.272.0002	9/3.3 MO	46	1.81	33	289	289	12	29	240	2
31.282.0002	9/4 MO	46	1.81	40	350	350	12	29	240	2
31.231.0001	11/4	59	2.32	40	350	279	18	21	330	3.3
31.241.0001	11/6	59	2.32	60	525	417	13	21	330	3.3
31.251.0002	11/8/	59	2.32	80	700	556	14	21	350	3.4
31.821.0001	11/10/	59	2.32	100	885	708	10	21	350	3.4
31.831.0003	11/4 MO	59	2.32	40	350	279	18	29	330	3.3
31.841.0003	11/6 MO	59	2.32	60	525	417	13	29	330	3.3
31.851.0003	11/8 MO	59	2.32	80	700	556	14	29	350	3.4
31.831.0002	11/10 MO	59	2.32	100	885	708	10	29	350	3.4

- Electrical cord length on motors is approximately 6 feet, for special requirements contact Elero USA.
- Most models are available in 230 volt, 50 Hz, contact factory for details.
- Higher capacity, heavy duty tubular motors in 230 volt are available, contact factory.

* These motors are also available with 32-turns at a surcharge. Please specify when ordering.

*1. 1 Newton meter= 8.85 inch lbs.

*2. Without system losses